

Grotime®

INFA GROUP

Crescent Chest 33142



Follow all manufacturer's assembly instructions carefully to ensure the safety features to the chest are not compromised.

Grotime

110-114 Old Bathurst Rd,
Emu Plains, NSW 2750

P.O. Box 487, Emu Plains,
NSW 2750

Customer Care

Email: customercare@infa.com.au

AUSTRALIA
1300 92 4632

www.grotime.com.au

NEW ZEALAND
067 590 870

www.grotime.co.nz

WARNINGS

It is **STRONGLY RECOMMENDED** that you **ANCHOR** this Product.

Toppling furniture can cause serious injuries and death.

This product has been fitted with an anchor strap. To prevent your furniture from tipping forward it is strongly recommended that you securely attach this product to a wall or other solid surface, using the anchor strap provided and appropriate fixings.

WARNING

FALL HAZARD: Children have suffered serious injuries after falling from change tables. Falls can happen quickly.

- **STAY** in arm's reach of your child.
- **ALWAYS** secure this unit to the support surface by (manufacturer's instructions for securing the changing unit). See instructions.

The recommended weight of the occupant placed on this changing table should not exceed 13.6kg.

- **DO NOT** use the add on changing unit if it is damaged or broken

- Never leave the child without supervision.
- Do not use this product if any part is broken, torn or missing.
- Keep small pieces away from children.
- FOLLOW THE MANUFACTURERS INSTRUCTIONS.
- DO NOT LEAVE CHILDREN UNATTENDED.
- RECOMMENDED CHANGE PAD SIZE:
 - 460mm (W) x 790mm (L) x 40mm (D)
- Suffocation Hazard: Babies have suffocated while sleeping on changing units: changing uits are not designed for a safe sleep.
- NEVER allow baby to sleep on changing unit.

01

B 46pcs

D 12pcs

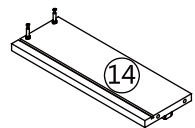
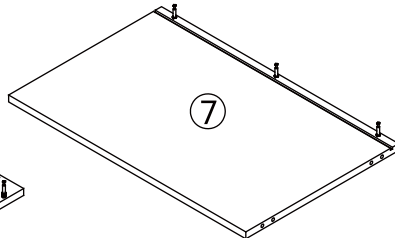
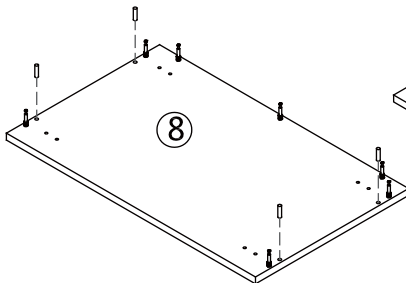
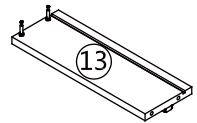
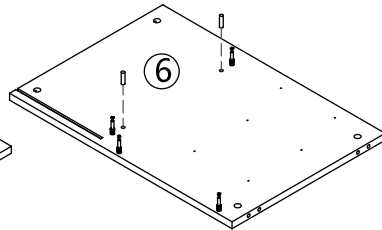
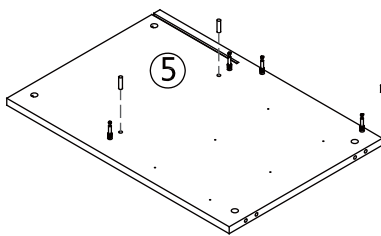
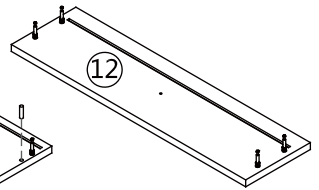
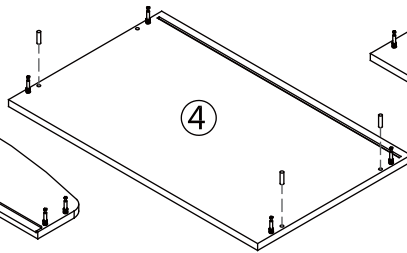
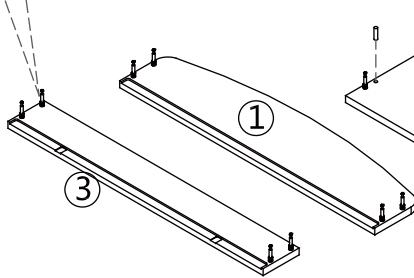
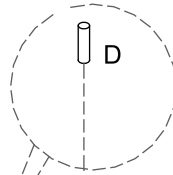
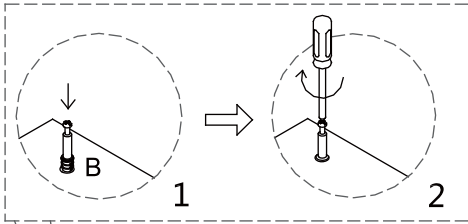
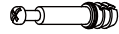

02

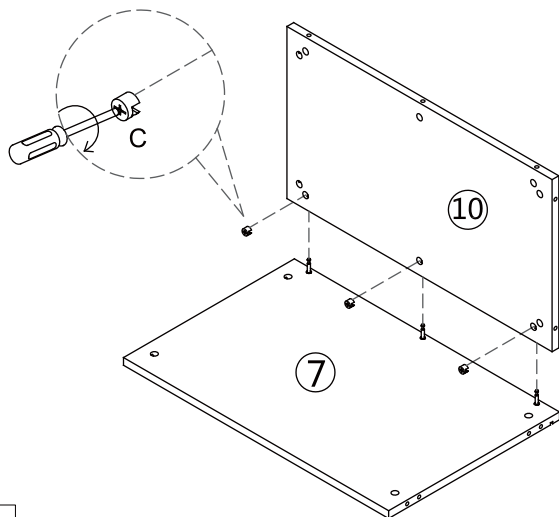

C 3pcs



03

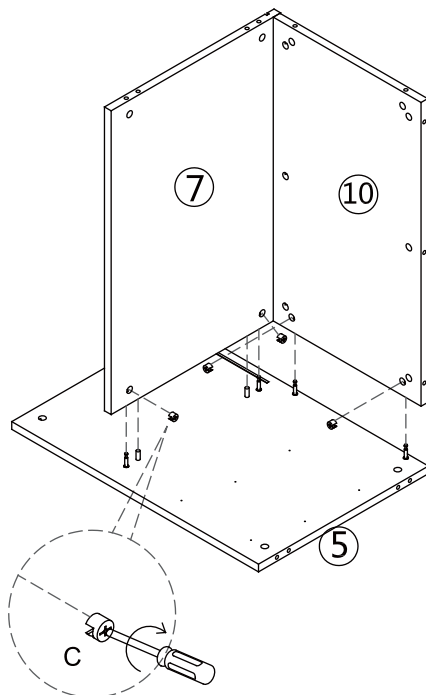

C 4pcs



04

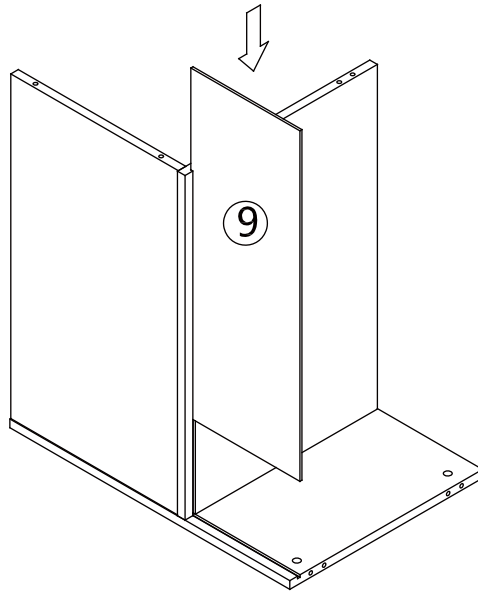

05

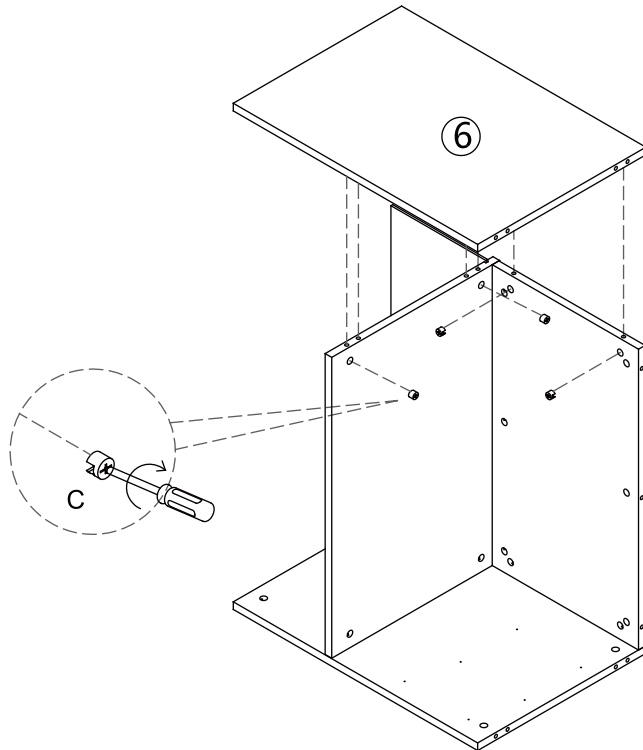

C 4pcs



06

C 4pcs

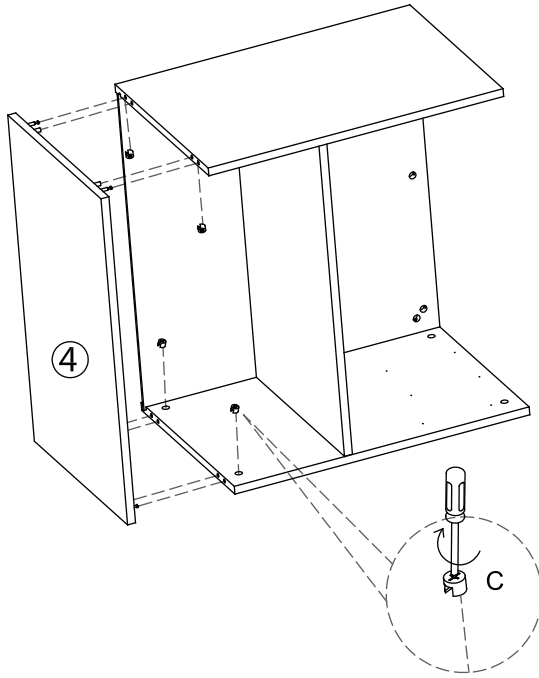

07

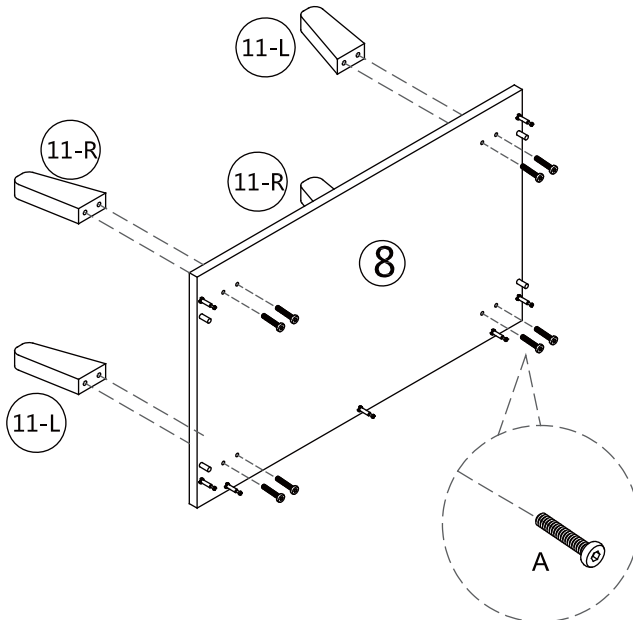

A M6*35=8pcs

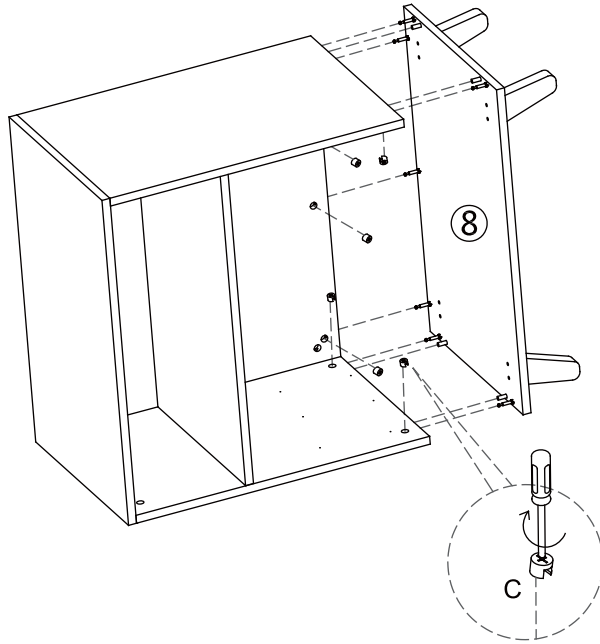

08

C 7pcs

**09**

P 2set



M M3.5*16=12pcs



The arrow of slide rail indicates the position correspondence.
Lock the screw M on the upper guide hole of the board.

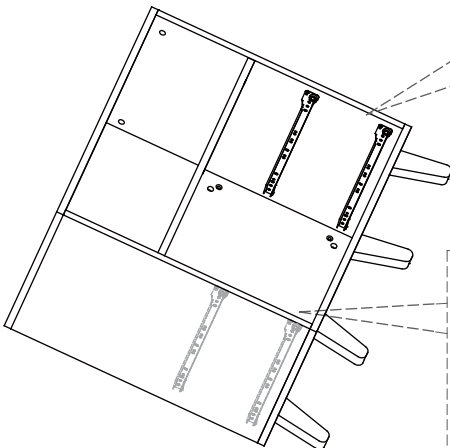
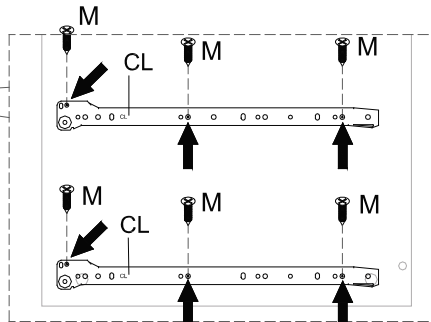
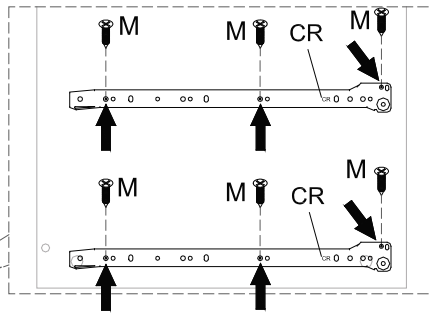

10

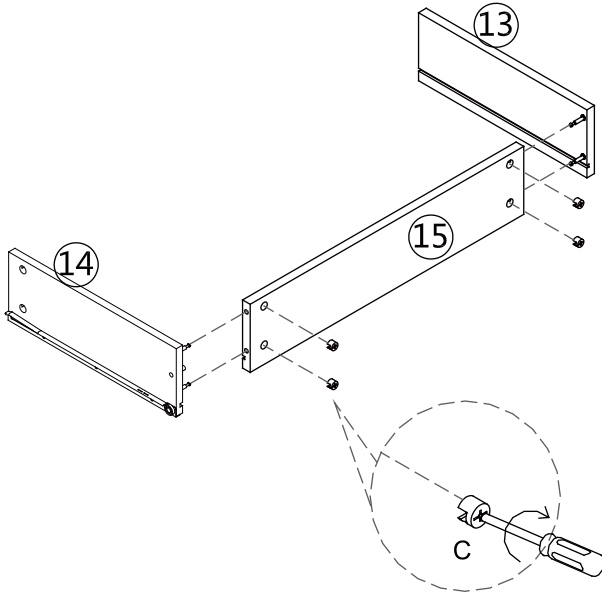

X2

C 8pcs



11

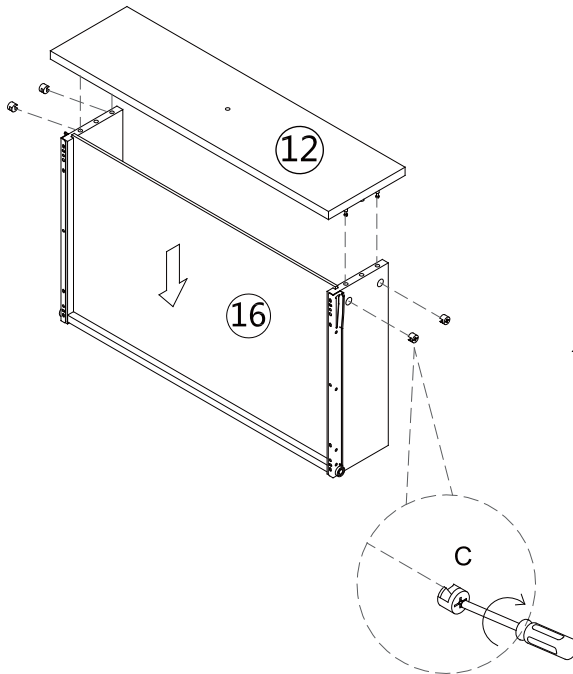

X2

C 8pcs



12

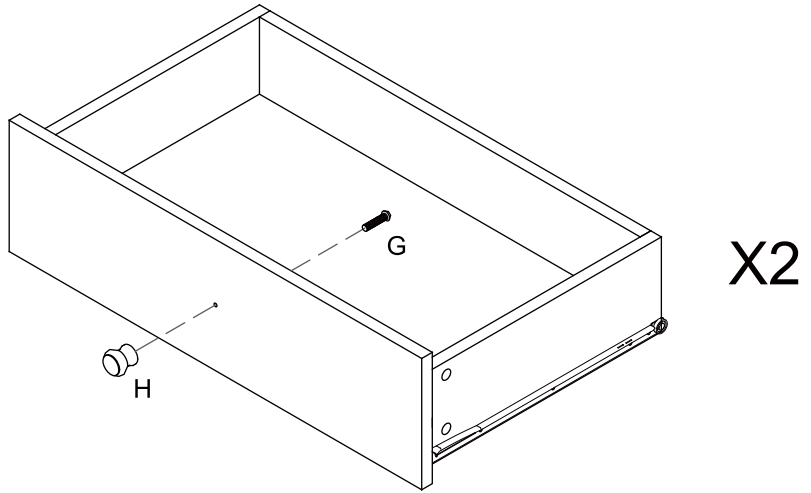

G M4*25=2pcs



H 2pcs



13

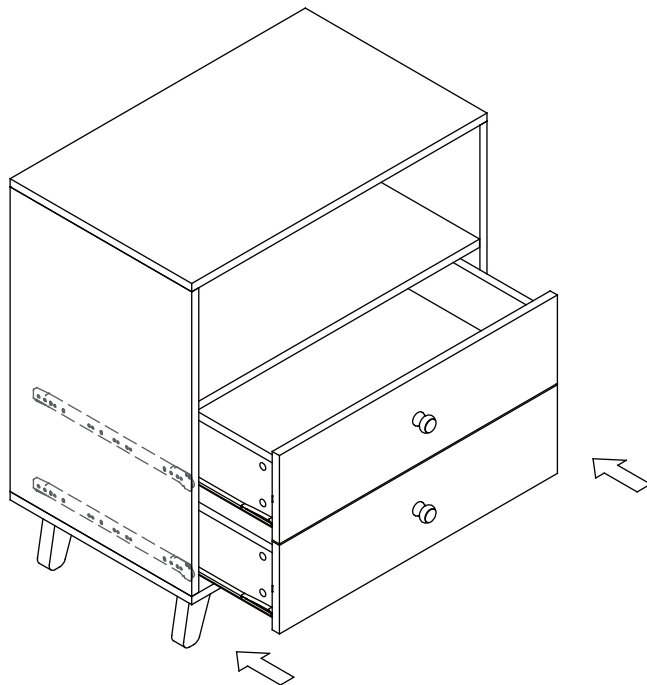

14

F 2pcs



E M3*10=2pcs



C 4pcs

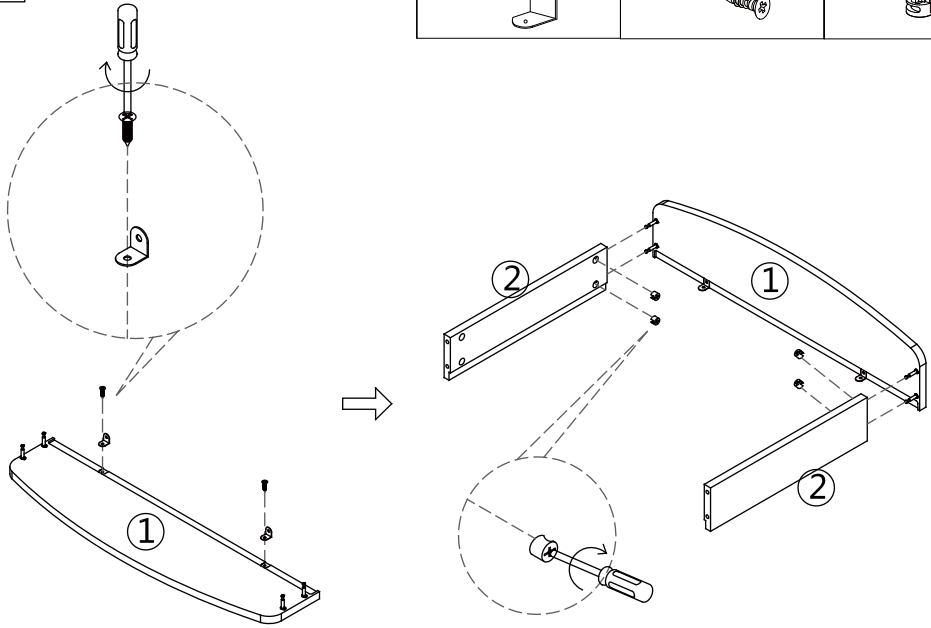

15

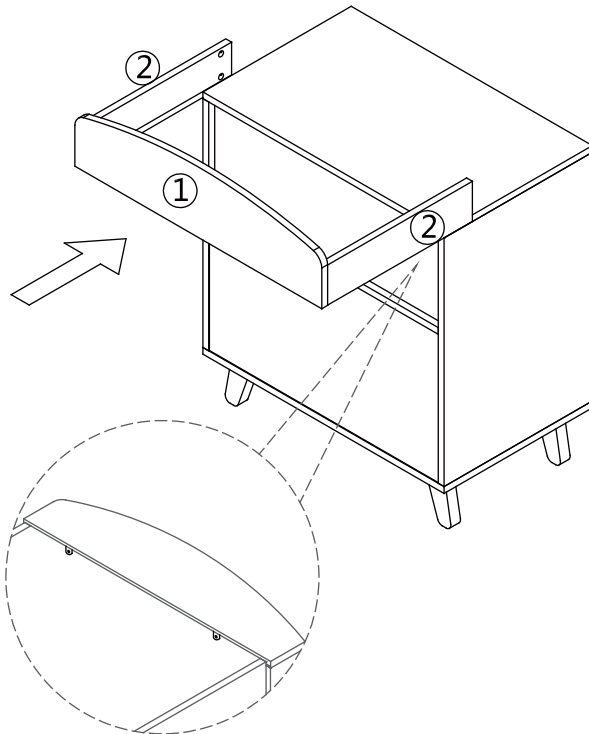

16

F 2pcs

E M3*10=2pcs

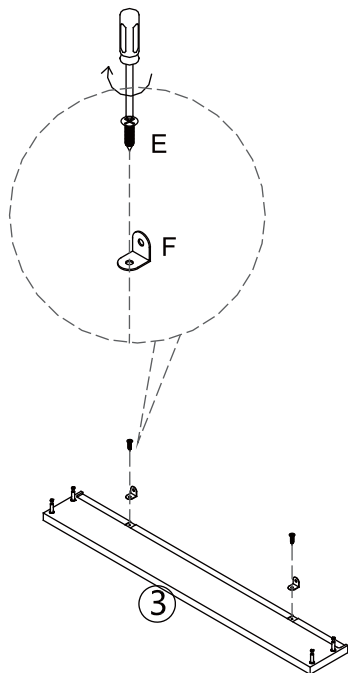

17

C 4pcs

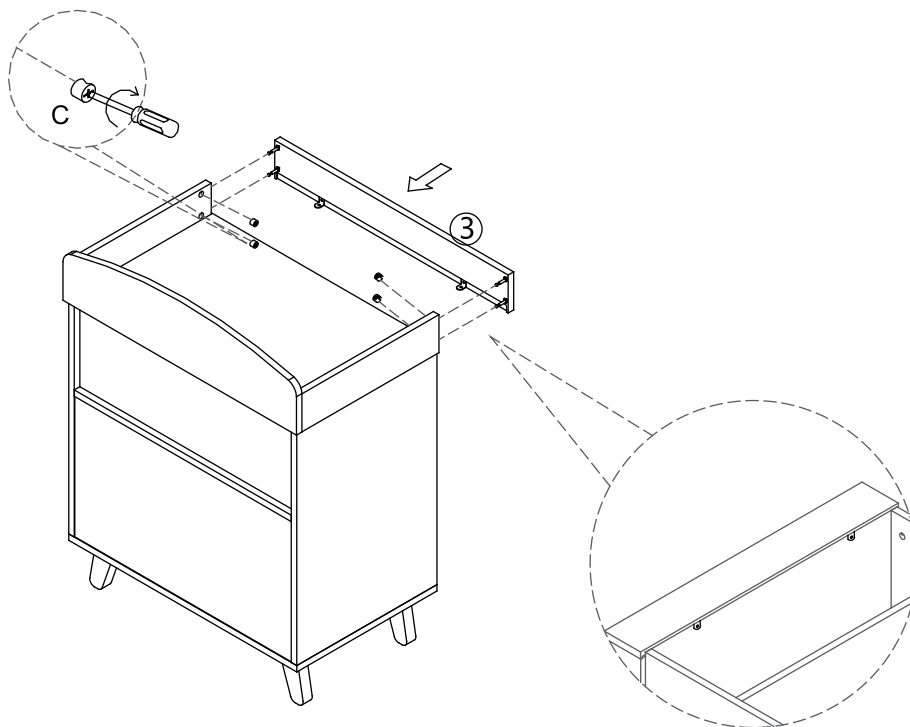

18

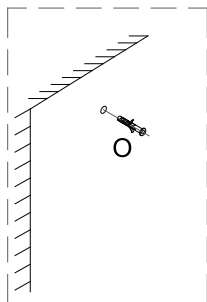
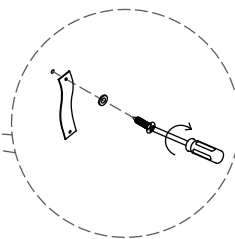
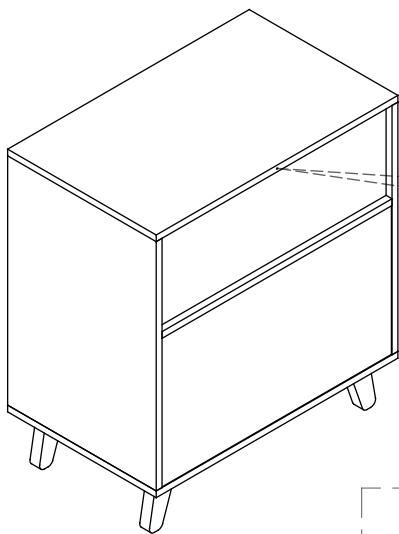
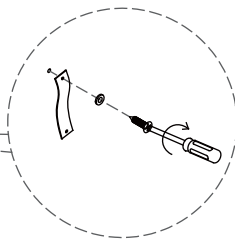
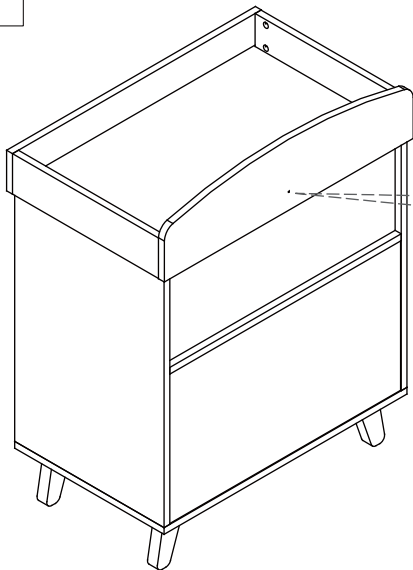

1

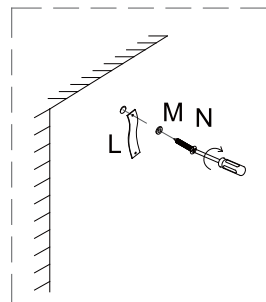

2

M M3.5*16=1pc



I 1pc



J 2pcs



K ST4*30=1pc



L 1pc



There is an anti-topple strap fixed to the back of the chest. Choose a suitable wall fixing and then fasten the strap to the wall as shown using the appropriate fixings.

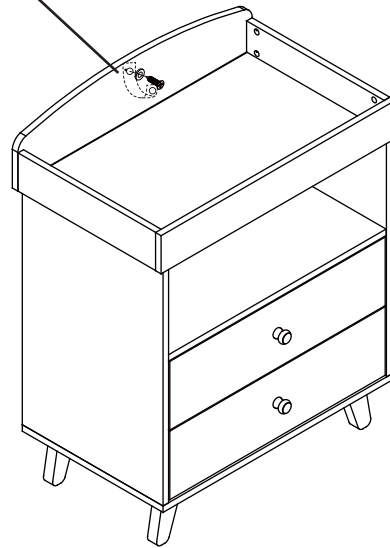
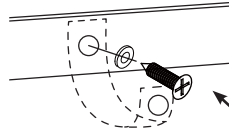

! WARNING !

When moving the chest, two persons are needed to lift from the bottom instead of the changer frame in case of dropping.

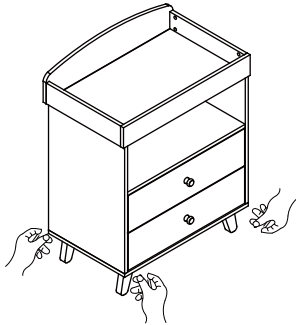

! WARNING !

WE STRONGLY RECOMMEND THAT THIS PRODUCT BE PERMANENTLY FIXED TO THE WALL OR OTHER SUITABLE SURFACE. PLEASE SEEK PROFESSIONAL ADVICE IF YOU ARE IN DOUBT WHAT FIXING DEVICE TO USE.

FURNITURE TRIP-OVER HAZARDS

Children like climbing on things, especially if there is something up high that they want. Household furniture like bookshelves, chests of drawers and entertainment units can be attractive to climb. So too furniture like tallboys where pulled-out drawers act as stairs for climbing.

The inclusion of the anchoring strap is supplied as per the recommendations of the Best Practice Guide for Furniture and Television Trip-Over Prevention, from the National Retail Association.

WARNING

It is **STRONGLY RECOMMENDED** that you **ANCHOR** this product.

Toppling furniture can cause serious injuries and death.

This product has been fitted with an anchor strap. To prevent your furniture from tipping forward it is strongly recommended that you securely attach this product to a wall or other solid surface, using the anchor strap provided and appropriate fixings.

IMPORTANT:

- Regularly check that anchors are securely maintained.
- Use safety drawer locks to prevent children climbing.
- Stability of tall items may be affected by thick pile carpet or uneven floors.
- Do not place unanchored televisions on furniture

CAUTION:

- For your safety when attaching the anchor fixings, please note the following:
- Check for any electrical wires or plumbing inside the wall before drilling any holes (if you are unsure please seek professional advice from a qualified trades person)
- Walls are constructed from different materials, for example, masonry (solid brick) or plasterboard lined cavity walls (hollow). It is important that you use the appropriate wall fixings for your wall type.
- Your local hardware store will have the necessary drills and fixings and can offer advice if needed. If in doubt, engage the services of a qualified trades person to install and anchor the product.

WARRANTY

Infa Group Pty Ltd warrants this product for 12 months from the date of purchase against failure due to manufacturing faults or faulty materials. Misuse, accidental damages, normal wear and tear are not covered by this warranty. When used for commercial use this period is limited to six months. “Our goods come with guarantees that cannot be excluded under the Australian Consumer Law. You are entitled to a replacement or refund of a major failure or for compensation for any other foreseeable loss or damage. You are entitled to have the goods repaired or replaced if the goods fail to be of acceptable quality and the failure does not amount to a major failure”.

STORAGE:

To store your 33142, please reverse assembly steps. Ensure all components are kept together along with Instruction manual for future use.

KEEP BOOKLET FOR FUTURE REFERENCE

READ ALL INSTRUCTIONS CAREFULLY BEFORE USE OF THIS CHANGE TABLE.
ALWAYS FOLLOW THE INSTRUCTIONS. THE CORRECT USE AND
MAINTENANCE OF THIS PRODUCT IS ESSENTIAL.

THIS PRODUCT IS NOT INTENDED FOR COMMERCIAL USE.

INFA GROUP PTY LTD
ABN: 52 149 173 660
110-114 Old Bathurst Rd,
Emu Plains, NSW 2750

CUSTOMER CARE
AU: 1300 92 4632
NZ: 067 590 870
Email: customer care@infa.com.au

MADE IN CHINA
MODEL NO:33142
ISSUE B