

Grotime®

INFA GROUP

Lilly Bassinet

31112

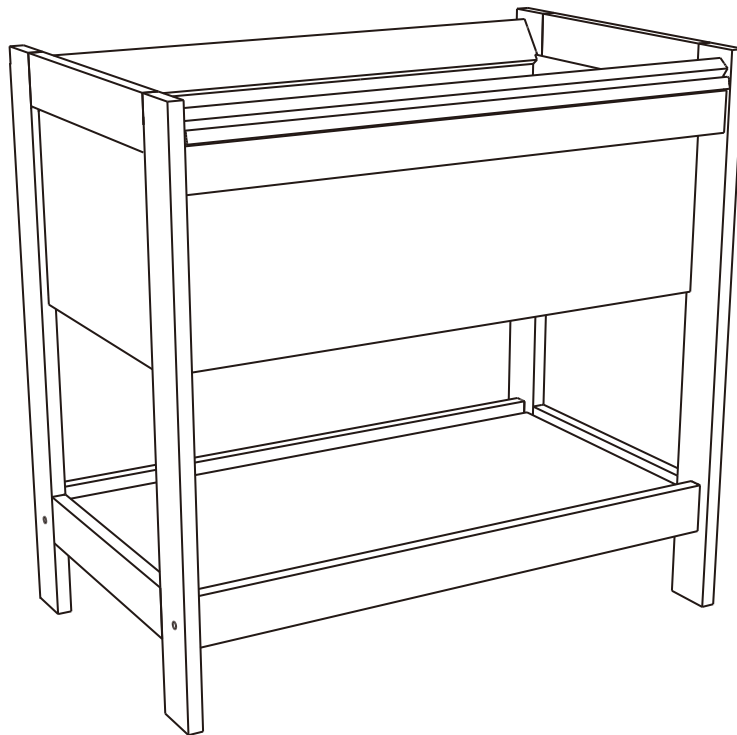

Two adults are required to assemble this change table



Follow all manufacturer's assembly instructions carefully to ensure the safety features of the change table are not compromised

Grotime

110-114 Old Bathurst Rd,
Emu Plains, NSW 2750

P.O. Box 487, Emu Plains,
NSW 2750

Customer Care

Email: customercare@infa.com.au

AUSTRALIA
1300 92 4632
www.grotime.com.au

NEW ZEALAND
067 590 870
www.grotime.co.nz

ISSUE B

KEEP BOOKLET FOR FUTURE REFERENCE

SAFETY INSTRUCTIONS:

Before using this product, read these instructions in their entirety, for assistance contact Grotime customer care:

AU: 1300 92 4632

NZ: 067 590 870

NOTE: The illustrations displayed throughout this booklet are for demonstration only, product specifications are subject to change without notice.

CARE AND MAINTENANCE

Check your change table regularly. Re-tighten all bolts. For customers care contact Grotime Australia on 1300 92 4632; or New Zealand on 067 590 870

Do not use abrasive or corrosive agents, lint free cloth and then wipe with a dry cloth.

WARNINGS

WARNING

- Do not use this product without reading the instructions for the use first
- Stop using the product as soon as the child can sit or kneel or pull itself up
- Placing additional items in the product may cause suffocation
- Do not place the product close to another product, which could present a danger of suffocation or strangulation, e.g. strings, blinds/curtain cords, etc.
- Do not use more than one mattress in the product

- The product should be placed on a horizontal floor
- Young children should not be allowed to play unsupervised in the vicinity of the crib
- All assembly fittings should always be tightened properly and that care should be taken that no screws are loose, because a child could trap parts of the body or clothing (e.g. strings, necklaces, ribbons for babies dummies, etc.), which would pose a risk of strangulation
- Be aware of the risk of burning cigarettes, open fires and other sources of strong heat, such as electric bar fires, gas fires, etc. in the near vicinity of the crib
- DO NOT use the crib if any parts are missing, damaged, or broken. Contact customer care@infa.com.au for replacement parts and instructional literature if needed. DO NOT substitute parts

WARNING - Only use the mattress sold with this crib, do not add a second mattress on this one, suffocation hazards

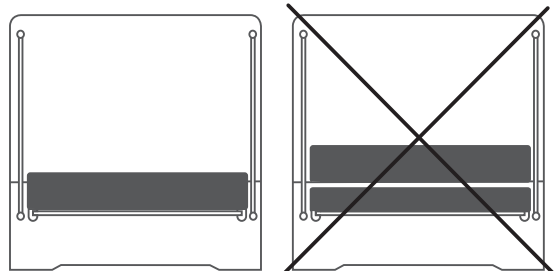

HARDWARE INVENTORY

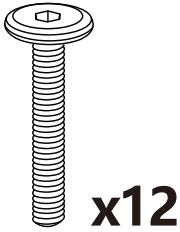

35mm Bolts

A

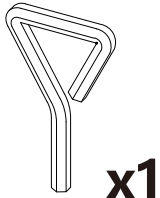

Allen Key

B



30mm Dowel

C

PARTS LIST

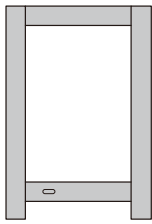

2xEnd panels

1

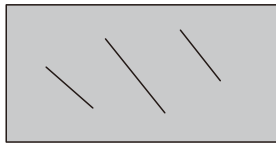

1xBassinette mattress

2



1x Bottom shelf plate

3

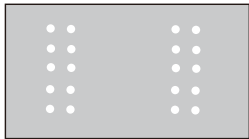

1x Bassinette mattress support

4

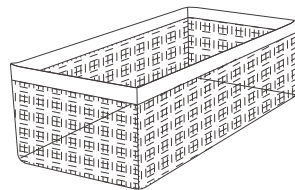

1x Bassinette liner

5



2x Top support side rails

6



2x Middle support side rails

7



2x Bottom shelf side rails

8



2x Plastic rod

9

STEP 1

ASSEMBLE DOWELS IN ALL SIDE RAILS

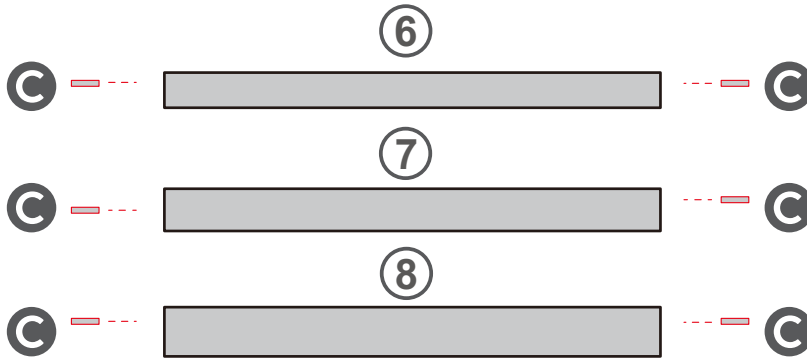
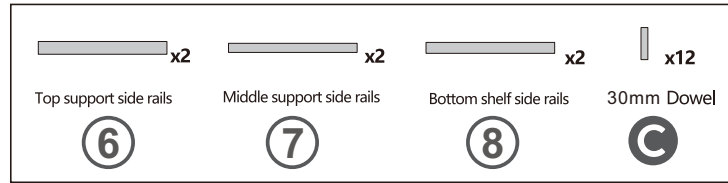

STEP 2

ASSEMBLE ALL SIDE RAILS TO ONE END

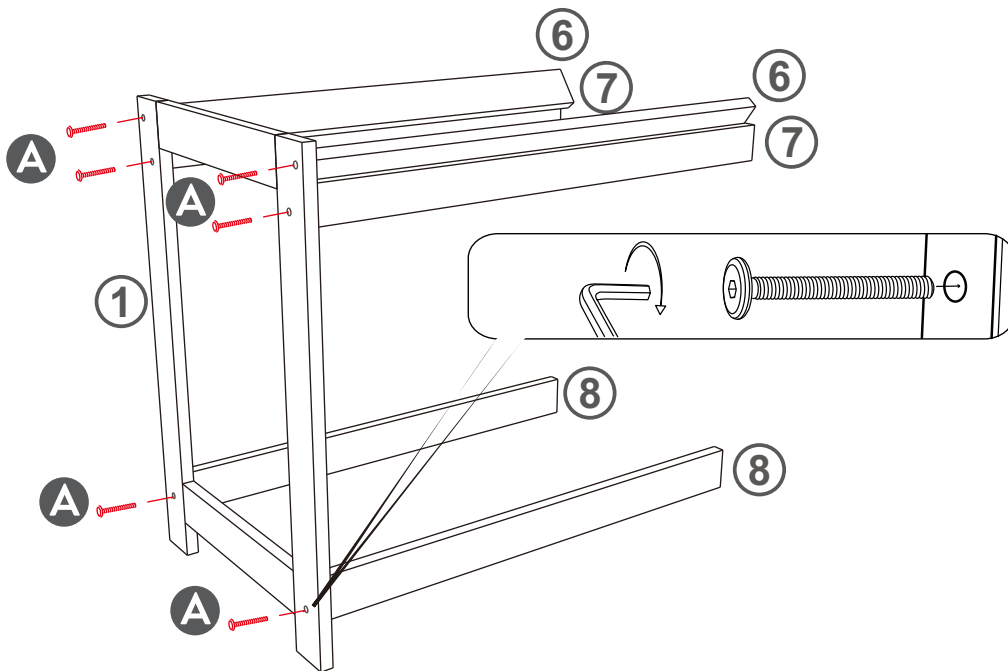
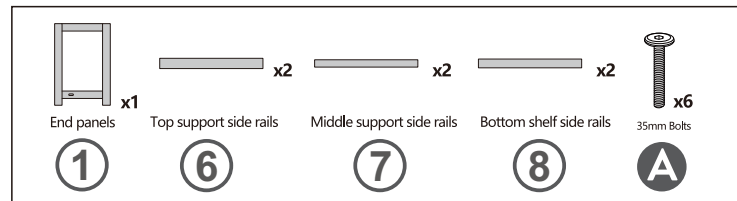

STEP 3

INSERT BOTTOM SHELF PLATE

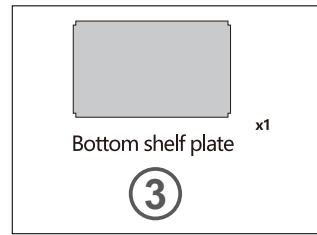
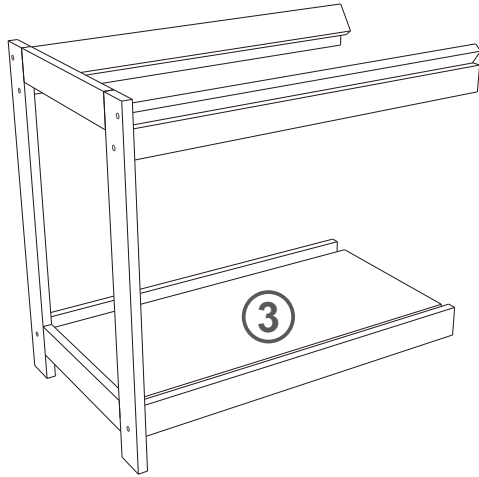

⚠ WARNING ⚠

BEFORE ASSEMBLING THE COT, ENSURE YOU HAVE A CLEAR AREA ON CARPET OR A THICK BLANKET OR RUG. NEVER ASSEMBLE ON A HARD SURFACE.

STEP 4

ASSEMBLE SECOND END PANEL

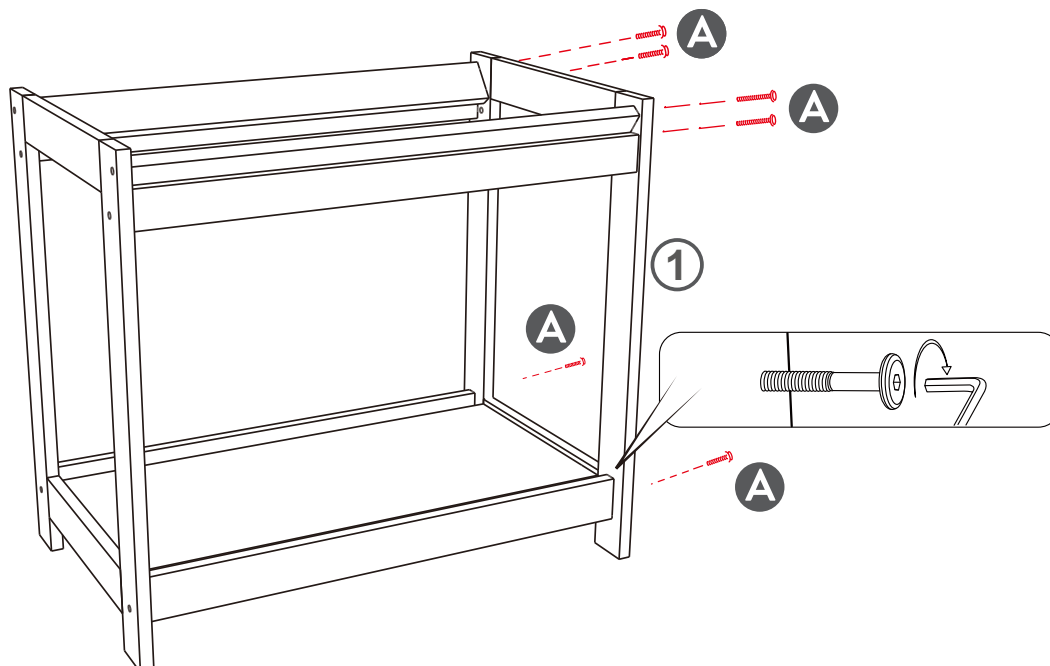
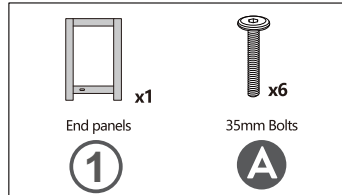

STEP 5

ASSEMBLE BASSINETTE LINER
MAKE SURE BASSINETTE LINER ENDS
ARE FIRMLY HELD BY VELCRO

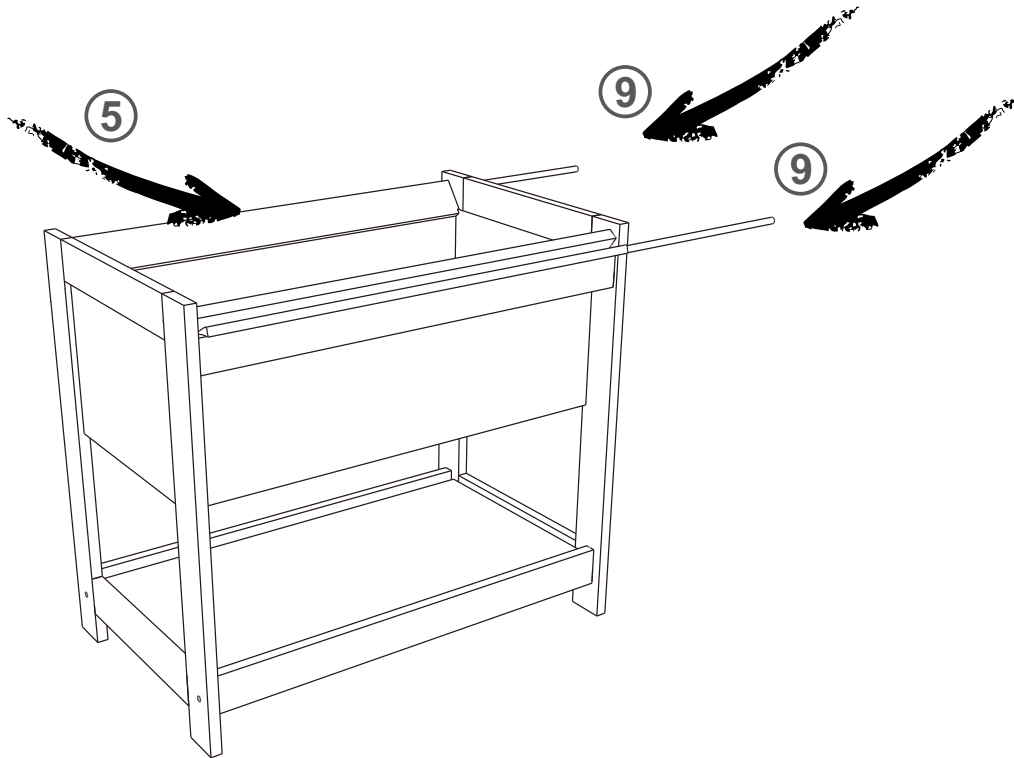
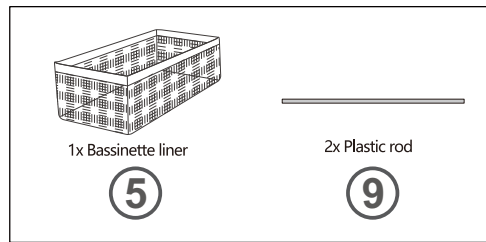

STEP 6

PLACE BASSINETTE MATTRESS SUPPORT IN
BASSINETTE LINER

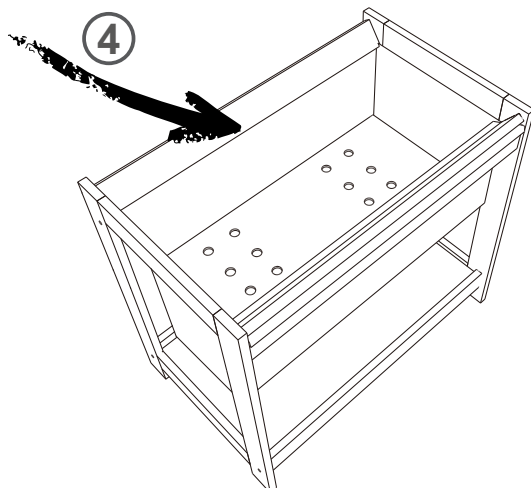
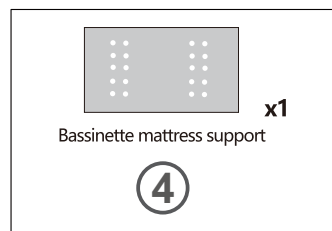

STEP 7

PLACE BASSINETTE MATTRESS IN BASSINETTE LINER

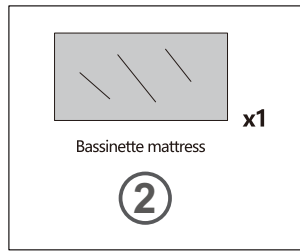
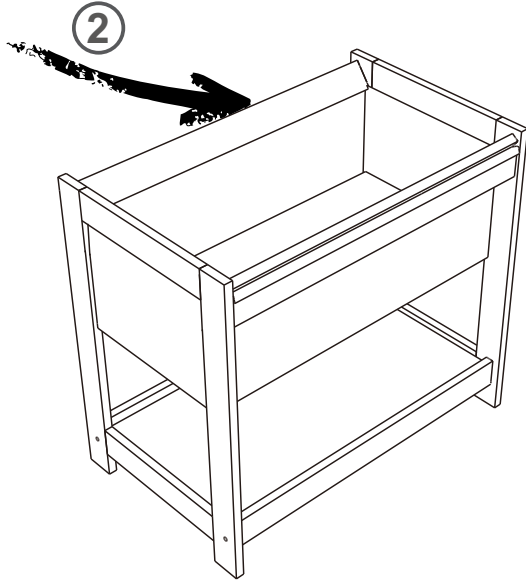

WARNING

BEFORE ASSEMBLING THE COT, ENSURE YOU HAVE A CLEAR AREA ON CARPET OR A THICK BLANKET OR RUG. NEVER ASSEMBLE ON A HARD SURFACE.

WARRANTY

Infa Group Pty Ltd warrants this product for 12 months from the date of purchase against failure due to manufacturing faults or faulty materials. Misuse, accidental damages, normal wear and tear are not covered by this warranty. When used for commercial use this period is limited to six months. “Our goods come with guarantees that cannot be excluded under the Australian Consumer Law. You are entitled to a replacement or refund of a major failure and for compensation for any other foreseeable loss or damage. You are entitled to have the goods repaired or replaced if the goods fail to be of acceptable quality and the failure does not amount to a major failure”.

STORAGE:

To store your 31112 , please reverse assembly steps. Ensure all components are kept together along with Instruction manual for future use.

KEEP BOOKLET FOR FUTURE REFERENCE

READ ALL INSTRUCTIONS CAREFULLY BEFORE USE OF THIS CHANGE TABLE.
ALWAYS FOLLOW THE INSTRUCTIONS. THE CORRECT USE AND
MAINTENANCE OF THIS PRODUCT IS ESSENTIAL.

THIS PRODUCT IS NOT INTENDED FOR COMMERCIAL USE.

INFA GROUP PTY LTD
ABN: 52 149 173 660
110-114 Old Bathurst Rd,
Emu Plains, NSW 2750

CUSTOMER CARE
AU: 1300 92 4632
NZ: 067 590 870
Email: customercare@infa.com.au

MADE IN CHINA
MODEL NO: 31112
ISSUE B