

# Cot

MODEL 30232

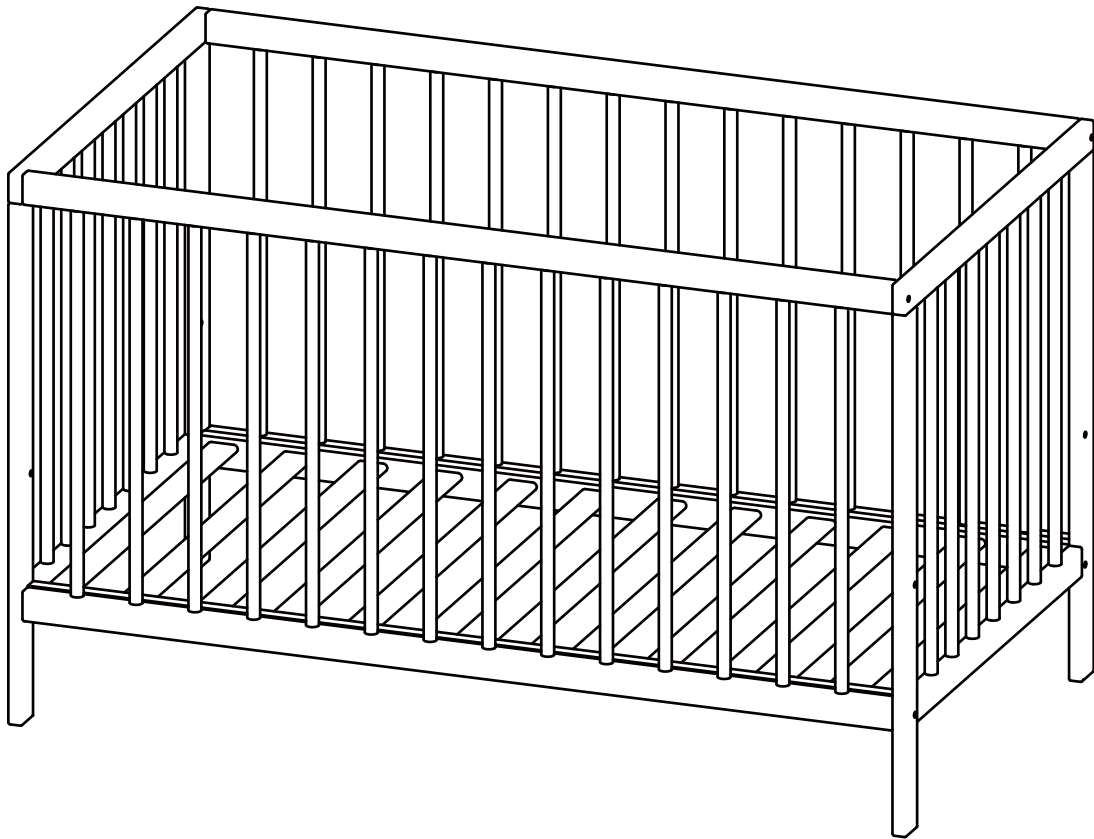

Two adults are required to assemble this cot



Follow all manufacturer's assembly instructions carefully to ensure the safety features of the cot are not compromised

## INSTRUCTIONS/WARNINGS

IMPORTANT. RETAIN FOR FUTURE REFERENCE. READ CAREFULLY

## SAFETY INSTRUCTIONS:

Before using this product, read these instructions in their entirety, for assistance contact Grottime customer care:

AU: 1300 92 4632

NZ: 067 590 870

NOTE: The illustrations displayed throughout this booklet are for demonstration only, product specifications are subject to change without notice. Assemble product according to manufacturers instructions.

## CARE AND MAINTENANCE

Check your cot regularly. Retighten all bolts. For customers care contact Grottime Australia on 1300 92 4632; or New Zealand on 067 590 870

Do not use abrasive or corrosive agents, lint free cloth and then wipe with a dry cloth.

## RECOMMENDED MATTRESS SIZE

This cot has been manufactured for use with a mattress which measures 690mm wide by 1300mm long and 130mm in thickness. The width and length are specified because it is important that the gaps between the mattress and the sides of the cot will not exceed 40mm when the mattress is pushed to one side or end, and 20mm when the mattress is centred in the cot. The thickness of the mattress has been specified to ensure that the depth of the it is greater than 500mm with the mattress base in the lower position to minimise the risk of a child climbing or falling out of the cot.

## STORAGE:

To store your Cot (30232), please reverse assembly steps. Ensure all components are kept together along with Instruction manual for future use.

**KEEP BOOKLET FOR FUTURE REFERENCE  
READ ALL INSTRUCTIONS CAREFULLY BEFORE USE OF THIS  
COT. ALWAYS FOLLOW THE INSTRUCTIONS. THE CORRECT USE AND  
MAINTENANCE OF THIS PRODUCT IS ESSENTIAL.**

**THIS PRODUCT IS NOT INTENDED FOR COMMERCIAL USE.**

## WARNINGS:

### **WARNING**

BEFORE ASSEMBLING THIS COT, ENSURE YOU HAVE A CLEAR AREA ON CARPET OR A THICK BLANKET OR RUG. NEVER ASSEMBLE ON A HARD SURFACE

### **WARNING**

TO PREVENT FALLS, THE MATTRESS BASE OF THIS COT SHOULD BE ADJUSTED TO THE LOWEST POSITION BEFORE CHILD CAN SIT UP.

### **WARNING**

TO PREVENT FALLS OR SUFFOCATION, THE MAXIMUM MATTRESS THICKNESS SHOULD NOT EXCEED 130MM

### **WARNING**

ENSURE YOUR CHOSEN LOCATION FOR THE COT IS A REASONABLE DISTANCE FROM CURTAINS, BLINDS, HEATERS, AND POWER POINTS. ALWAYS KEEP MEDICATION, STRING, ELASTIC, SMALL TOYS OR SMALL ITEMS SUCH AS MONEY OUT OF REACH FROM ANY POSITION IN THE COT

## CONTENTS:

Before using this product remove and check all components within the packaging for scratches or dents.

## PARTS INVENTORY:

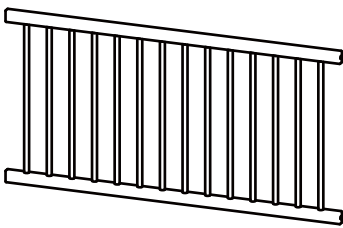

① Fixed Side x2

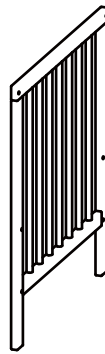

② Cot End x2

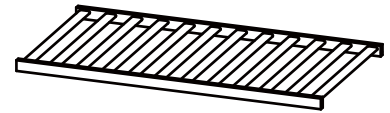

③ Cot Base x1

## HARDWARE INVENTORY:

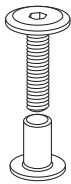

A 16mm Bolts & Cap Nut  
x 4

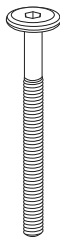

B 60mm Bolts  
x 12

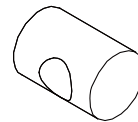

C Barrel Nut  
x 12



D Allen Key  
x 2

### ⚠ WARNING ⚠

BEFORE ASSEMBLING THE COT, ENSURE YOU HAVE A CLEAR AREA ON CARPET OR A THICK BLANKET OR RUG. NEVER ASSEMBLE ON A HARD SURFACE.

## ASSEMBLY

The improper assembly of this product can lead to serious injury of your child. Ensure that the 30232 is assembled as per these instructions.

### WARNING:

Please keep all packaging material away from the babies and children to prevent suffocation.

**Step 1.** Unpack Contents.

**Step 2.** Assemble 1 x Fixed Side (1) to 2 x Cot Ends (2) using 4 x 60mm Bolts (B) & 4 x Barrel Nuts (C).

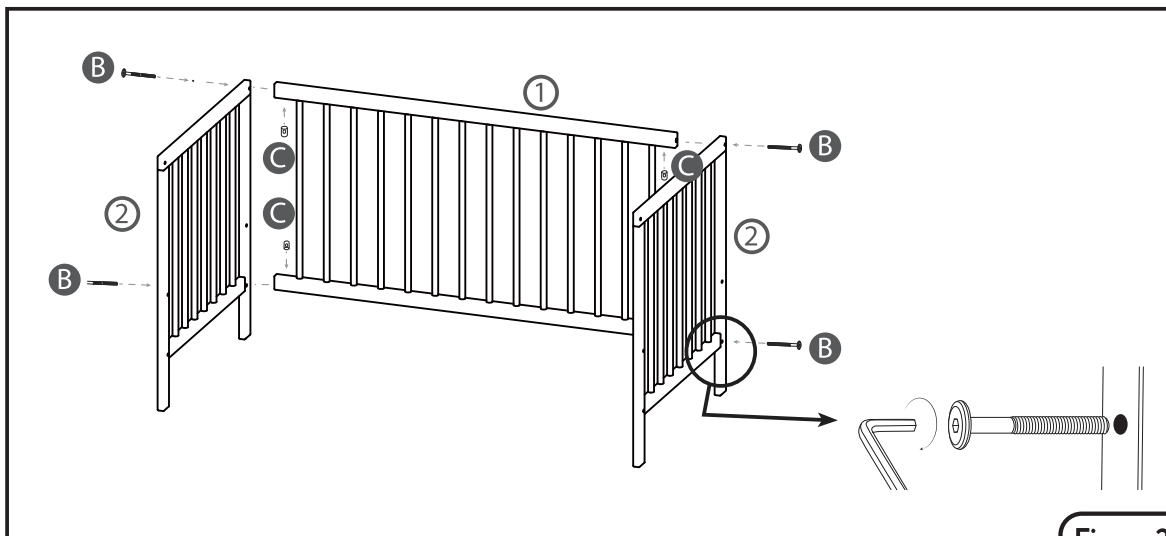

Figure 2A

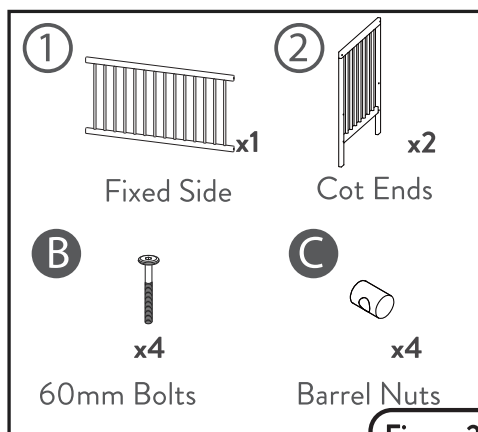

Figure 2B

### ⚠ WARNING ⚠

TO PREVENT FALLS, THE MATTRESS BASE OF THIS COT SHOULD BE ADJUSTED TO THE LOWEST POSITION BEFORE CHILD CAN SIT UP.

## ASSEMBLY

### Step 3.

Assemble Cot base (3) using 4 x 60mm Bolts (B) & 4 x Barrel Nuts (C).

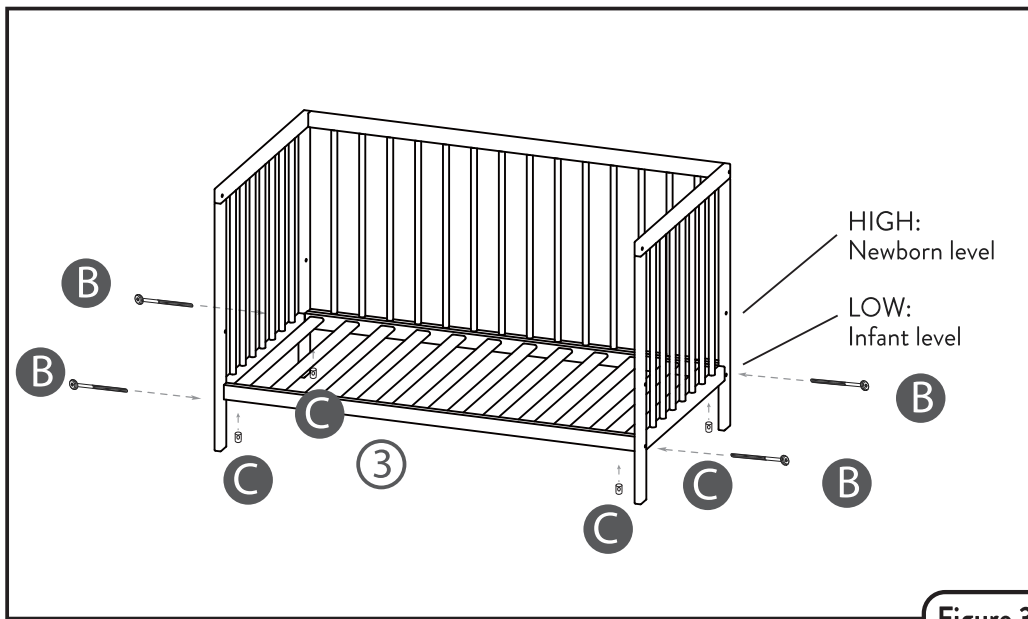

Figure 3A

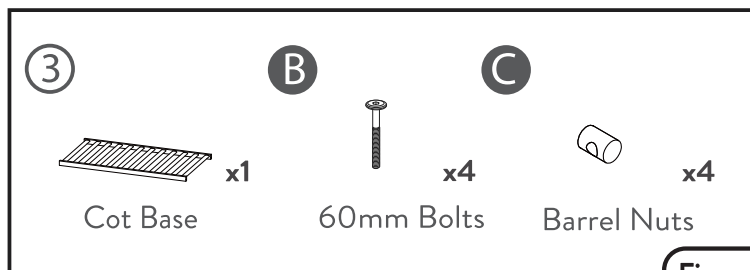
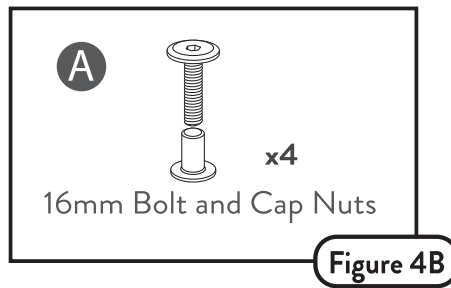
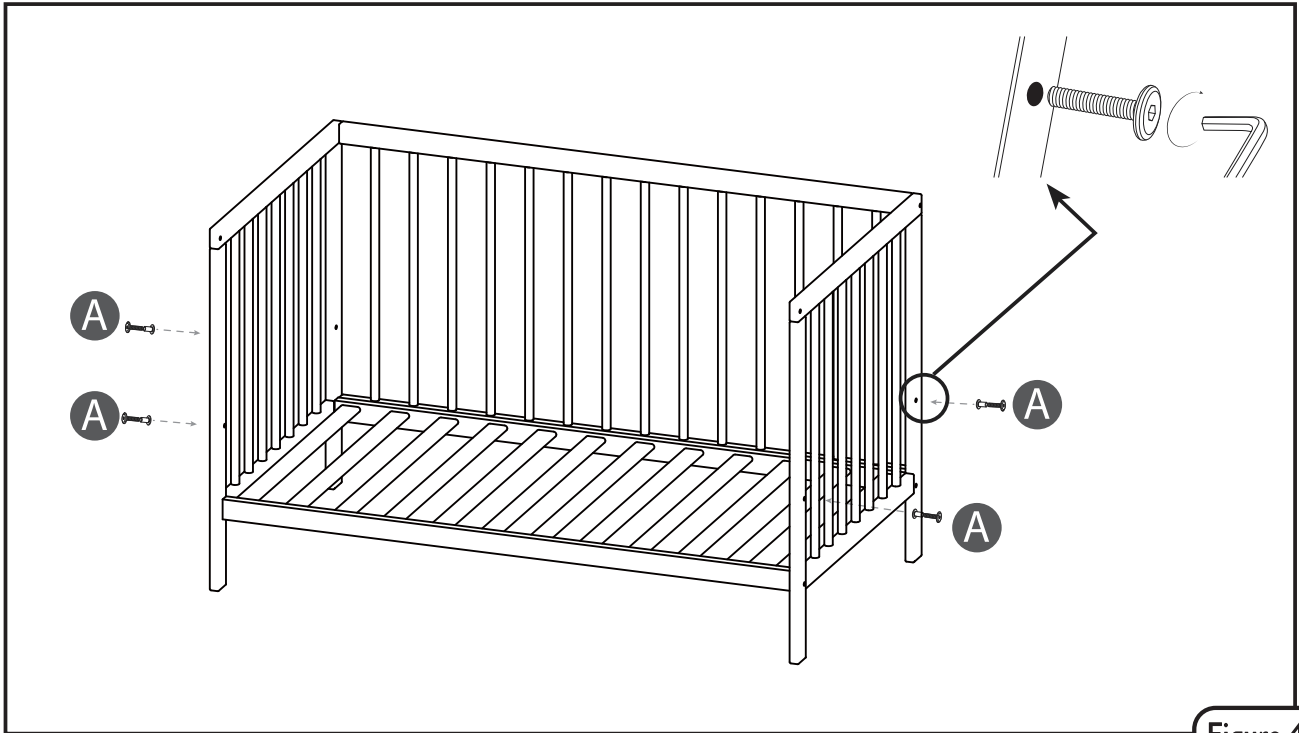

Figure 3B

- ❗ Do not tighten bolts at this stage
- ❗ Choose high or low position for mattress base

## ASSEMBLY

**Step 4.** Plug finger entrapments with 4 x 16mm Bolts & Cap Nuts (A)



## ASSEMBLY

**Step 5.** Assemble final Fixed Side (1) using 4 x 60mm Bolts (B) and 4 x Barrel Nuts (C).

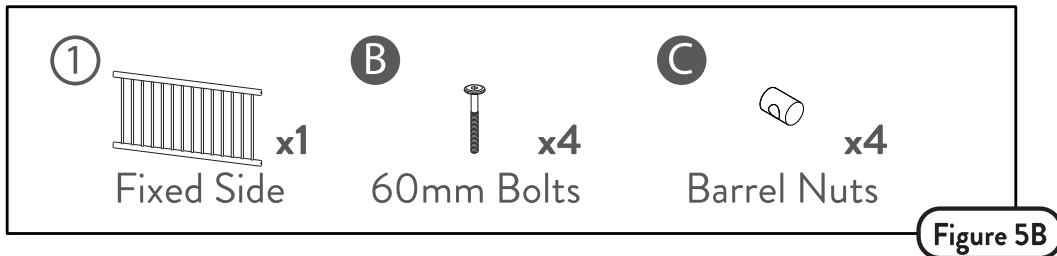
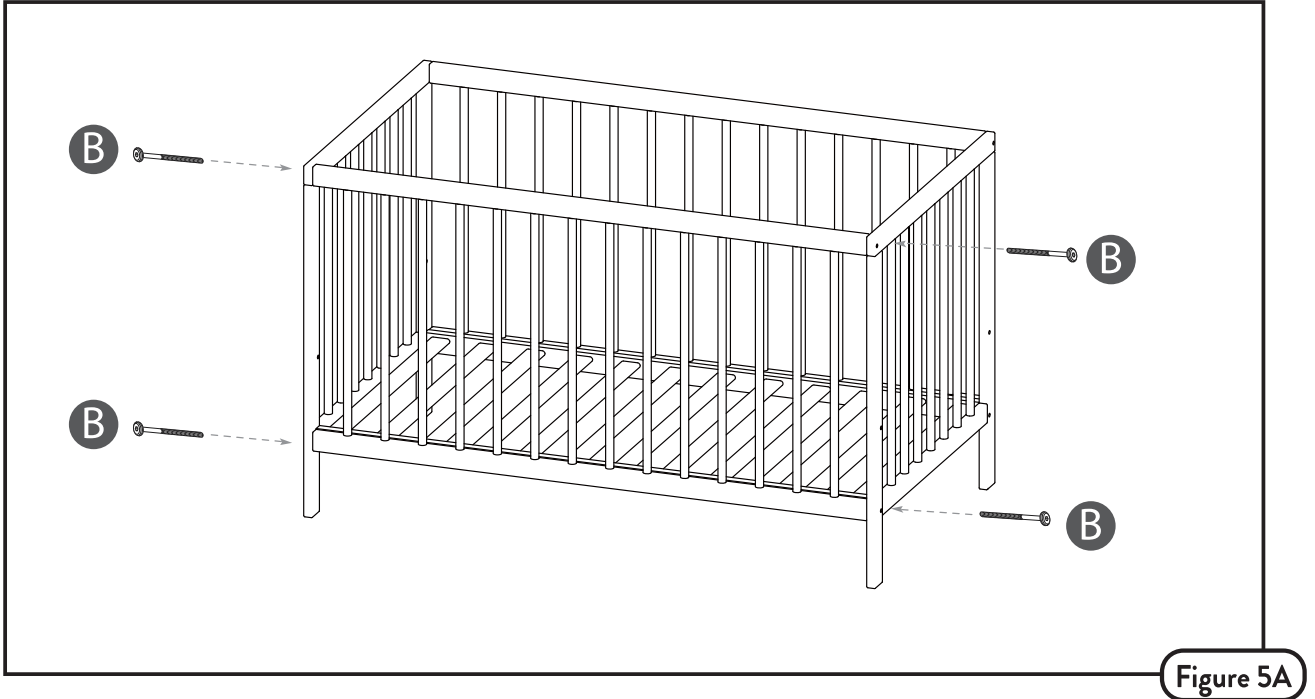



## ASSEMBLY

Step 6. Tighten all bolts.

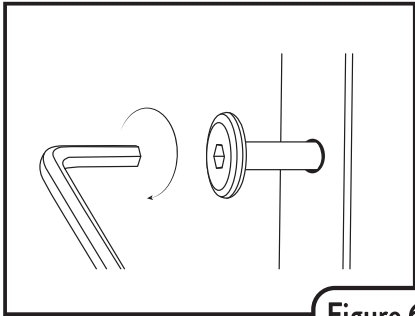

Figure 6A

## ⚠ WARNING ⚠

ENSURE YOUR CHOSEN LOCATION FOR THE COT IS A REASONABLE DISTANCE FROM CURTAINS, BLINDS, HEATERS, AND POWER POINTS. ALWAYS KEEP MEDICATION, STRING, ELASTIC, SMALL TOYS OR SMALL ITEMS SUCH AS MONEY OUT OF REACH FROM ANY POSITION IN THE COT.

## DAY BED CONVERSION

Remove Fixed Side by reversing Step 4.

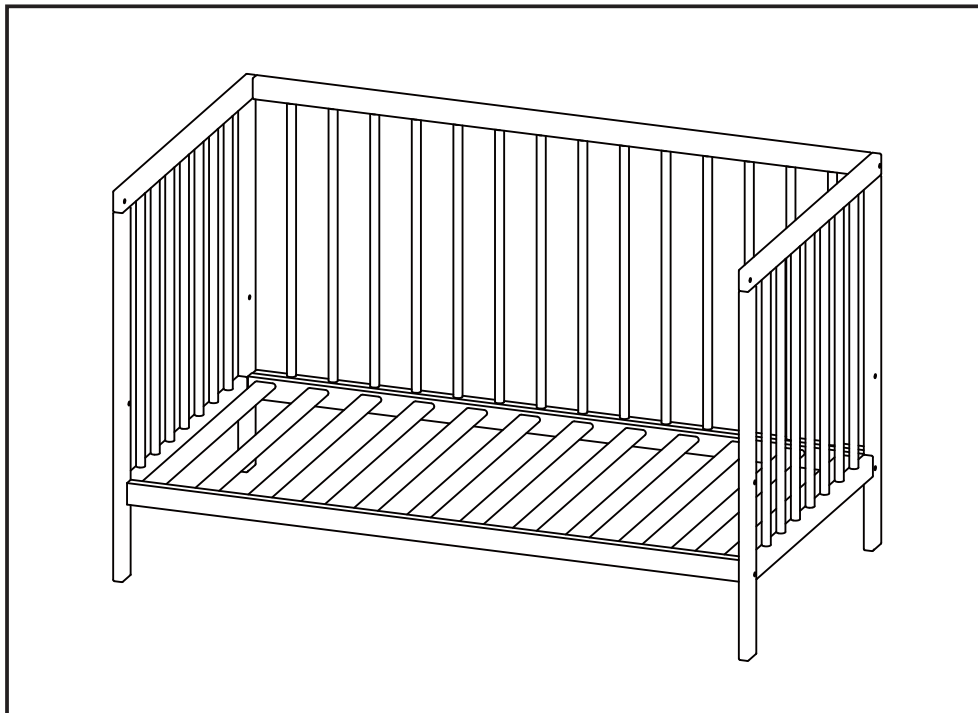



## NOTES

---

---

---

---

---

---

---

---

---

---

---

---

---

---

---

---

---

---

---

---

---

---

---

---

---

---

---

---

---

---

## WARRANTY

Infa Group Pty Ltd warrants this product for 12 months from the date of purchase against failure due to manufacturing faults or faulty materials. Misuse, accidental damages, normal wear and tear are not covered by this warranty. When used for commercial use this period is limited to six months. “Our goods come with guarantees that cannot be excluded under the Australian Consumer Law. You are entitled to a replacement or refund of a major failure or for compensation for any other foreseeable loss or damage. You are entitled to have the goods repaired or replaced if the goods fail to be of acceptable quality and the failure does not amount to a major failure”.

## STORAGE:

To store your 30232, please reverse assembly steps. Ensure all components are kept together along with Instruction manual for future use.

## KEEP BOOKLET FOR FUTURE REFERENCE

READ ALL INSTRUCTIONS CAREFULLY BEFORE USE OF THIS COT.  
ALWAYS FOLLOW THE INSTRUCTIONS. THE CORRECT USE AND  
MAINTENANCE OF THIS PRODUCT IS ESSENTIAL.

THIS PRODUCT IS NOT INTENDED FOR COMMERCIAL USE.

[www.grotime.com.au](http://www.grotime.com.au)  
[www.grotime.co.nz](http://www.grotime.co.nz)

INFA GROUP PTY LTD  
ABN: 52 149 173 660  
110-114 Old Bathurst Rd,  
Emu Plains, NSW 2750

CUSTOMER CARE  
AU: 1300 92 4632  
NZ: 067 590 870  
Email: [customercare@infa.com.au](mailto:customercare@infa.com.au)

MADE IN CHINA  
MODEL NO: 30232  
ISSUE B