

Timber Change Table

MODEL 35114

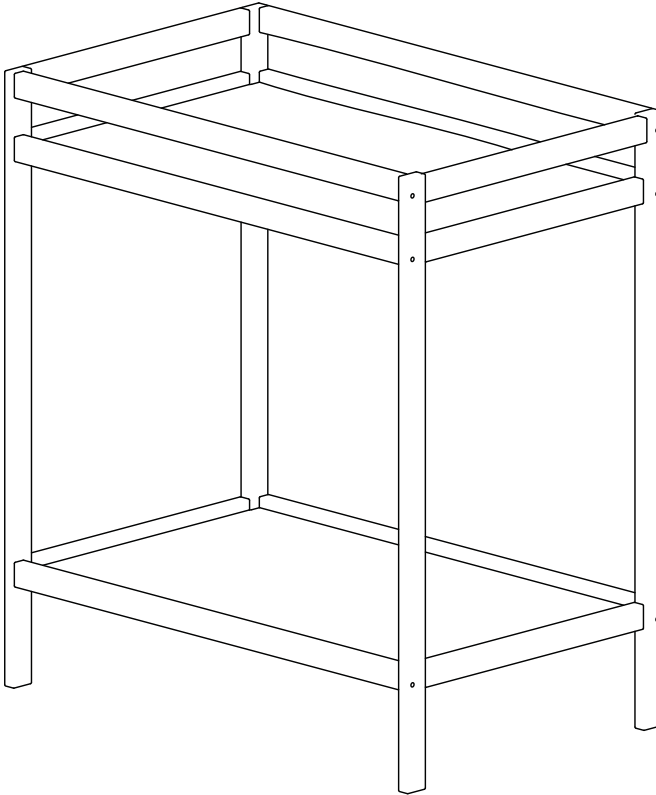

INSTRUCTIONS/WARNINGS

READ ALL INSTRUCTIONS CAREFULLY BEFORE USE OF THIS CHANGE TABLE

SAFETY INSTRUCTIONS:

Before using this product, read these instructions in their entirety, for assistance contact Infa Group customer care:

AU: 1300 92 4632

NZ: 067 590 870

NOTE: The illustrations displayed throughout this booklet are for demonstration only, product specifications are subject to change without notice.

CARE AND MAINTENANCE

Check your change table regularly. Re-tighten all bolts. For customers care contact Infa Group Australia on 1300 92 4632; or New Zealand on 067 590 870

Do not use abrasive or corrosive agents, lint free cloth and then wipe with a dry cloth.

WARNINGS

WARNING

FALL HAZARD: Children have suffered serious injuries after falling from changing tables. Falls can happen quickly.

- **STAY** in arm's reach of your child.
 - Read all instructions before use of this product.
 - Do not use product if it is damaged or broken.
 - The baby's maximum weight for use of this product is 13.6kg.
-
- Never leave the child without supervision.
 - Do not use this product if any part is broken, torn or missing.
 - Keep small pieces away from children.
 - FOLLOW THE MANUFACTURERS INSTRUCTIONS.
 - DO NOT LEAVE CHILDREN UNATTENDED.
 - THIS CHANGE TABLE MUST BE USED IN CONJUNCTION WITH A CONTOURED CHANGE PAD - SIZE: 490mm (W) x 790mm (L) x 40mm (D)
 - RECOMMENDED CONTOURED CHANGE PAD SIZE:
 - Changing Surface: 490mm (W) x 790mm (L) x 40mm (D)
 - Recommended Change Pad:
 - CP10 (490mm x 790mm)
 - 35109 (490mm x 790mm)

CONTENTS:

Before using this product remove and check all components within the packaging for scratches or dents. After use, dispose of the product in an environmentally friendly manner at your local recycling centre.

HARDWARE INVENTORY

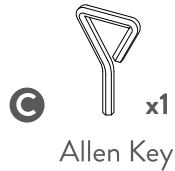
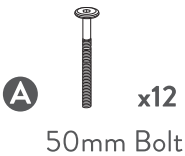

PARTS INVENTORY

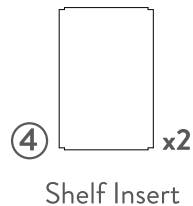
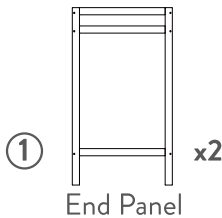

ASSEMBLY

The improper assembly of this product can lead to serious injury of your child. Ensure that the 35114 Change Table is assembled as per these instructions.

Step 1. Unpack contents.

Step 2. Attach the Top & Bottom Shelf Side Rails (2 & 3) to the End Panel (1) by using 6 x 50mm Bolts (A), 6 x Wood Dowels (B) & 6 x Barrel Nut (D).

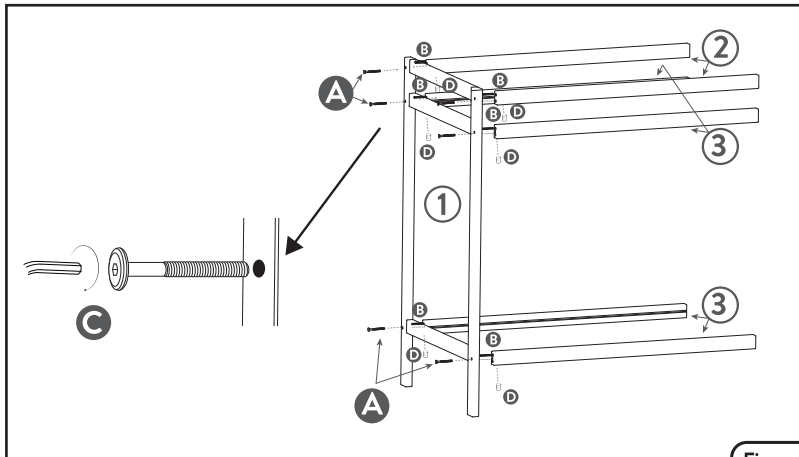

Figure 2A

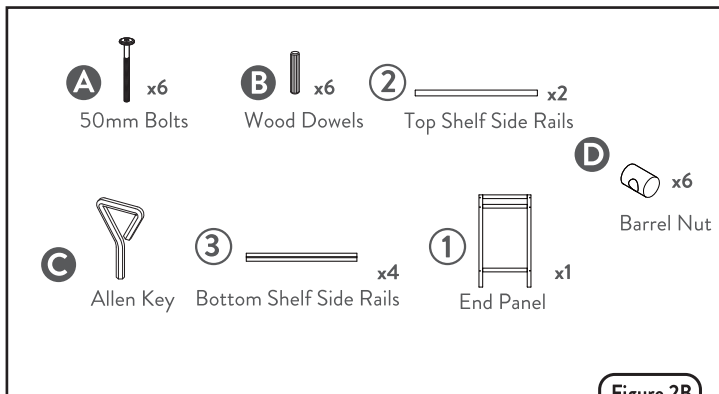

Figure 2B

ASSEMBLY

Step 3. Attach 2 x Shelf Inserts (4) to the sub assembly from step 2.

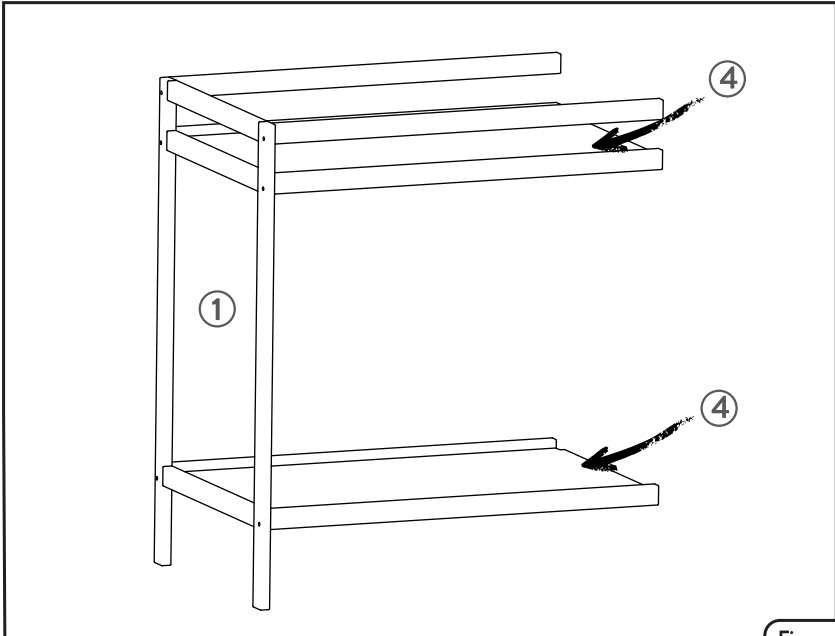

Figure 3A

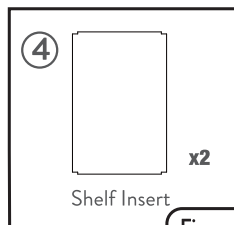

Figure 3B

PRODUCT USE

Step 4. Attach End Panel (1) to the sub assembly from step 3 by using 6 x 50mm Bolts (A), 6 x Wood Dowels (B) & 6 x Barrel Nut (D).

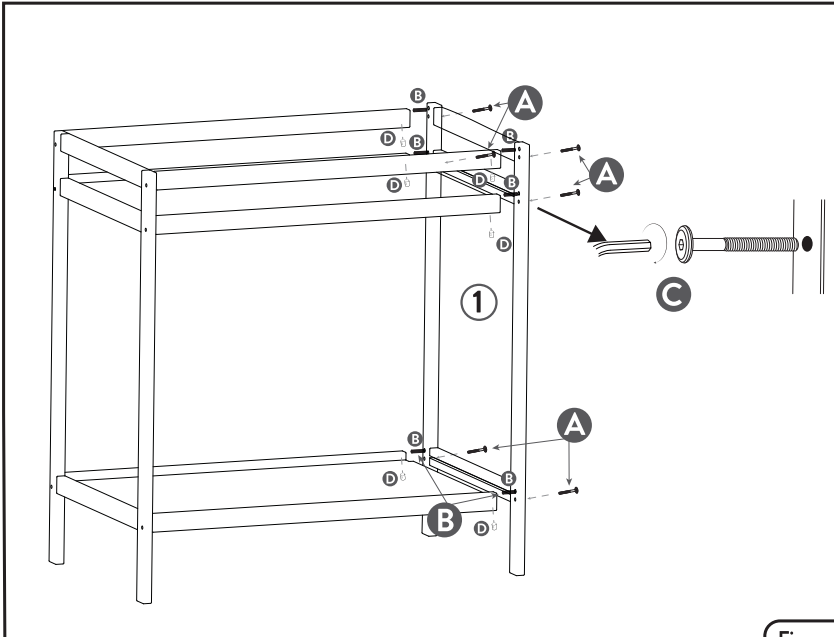

Figure 4A

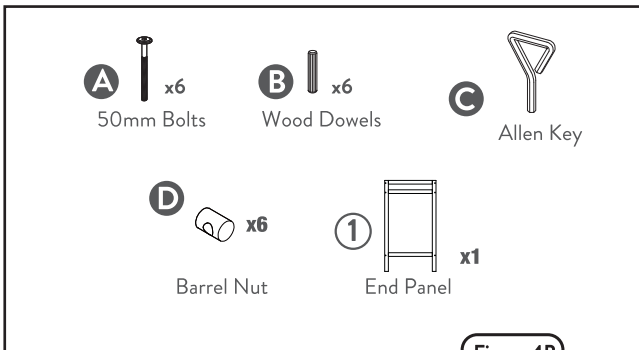

Figure 4B

PRODUCT USE

Step 5. Your 35114 Change Table Is now complete and ready to be used.

Note: Ensure that all Bolts are tightened before use!

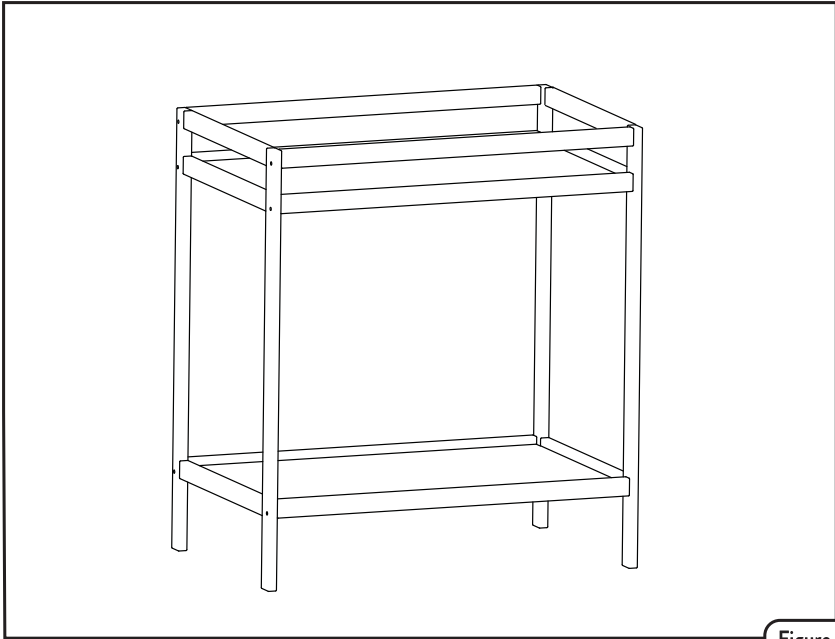
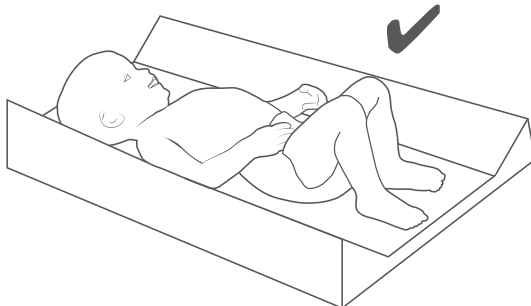

Figure 5A

WARNING: Only place infant long ways on the change pad.

It is unsafe and not recommended to position the infant side ways.



WARRANTY

Infa Group Pty Ltd warrants this product for 12 months from the date of purchase against failure due to manufacturing faults or faulty materials. Misuse, accidental damages, normal wear and tear are not covered by this warranty. When used for commercial use this period is limited to six months. “Our goods come with guarantees that cannot be excluded under the Australian Consumer Law. You are entitled to a replacement or refund of a major failure or for compensation for any other foreseeable loss or damage. You are entitled to have the goods repaired or replaced if the goods fail to be of acceptable quality and the failure does not amount to a major failure”.

STORAGE:

To store your 35114, please reverse assembly steps. Ensure all components are kept together along with Instruction manual for future use.

KEEP BOOKLET FOR FUTURE REFERENCE

READ ALL INSTRUCTIONS CAREFULLY BEFORE USE OF THIS CHANGE TABLE.
ALWAYS FOLLOW THE INSTRUCTIONS. THE CORRECT USE AND
MAINTENANCE OF THIS PRODUCT IS ESSENTIAL.

THIS PRODUCT IS NOT INTENDED FOR COMMERCIAL USE.